

Global Packaging



# BAKERY, BISCUITS AND CONFECTIONERY

Packaging solutions

| EN



# Bakery, biscuits and confectionery

## Specialists in bakery, biscuits and confectionery

This sector needs flexible packaging solutions that guarantee products are marketed in a presentation that is appropriate for traditional products, in attractive and easy to use packages.

**ULMA** is fully aware that its clients' success depends on the quality of their products and their presentation at the point of sale, and therefore places its experience of over 50 years at their disposal offering solutions for packaging their products to the highest standards of quality and efficiency while maintaining their traditional appearance.

## Global Offer

**ULMA** offers a wide range of solutions for the sector, from manual packaging machines to turnkey systems, from product handling and distribution of single product to final palletization.



## Packaging systems

**COMPLETE SOLUTIONS** inclusive of product distribution systems, primary and secondary packaging, complemented by inspection and quality control systems, weighing, labelling, etc. integrated in the packaging line.

**ULMA** develops customised solutions at its technology centre including vision inspection systems, and product loading/unloading robots according to each client's needs.

Its product range is completed with internal logistics transport systems for empty and/or filled boxes as well as stacking systems.

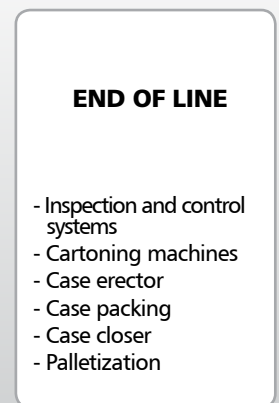
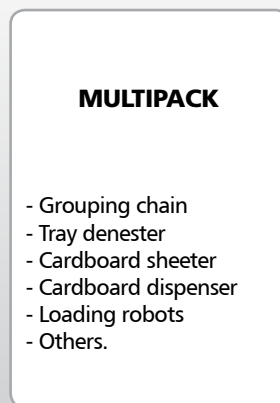
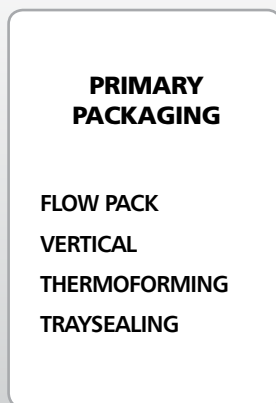
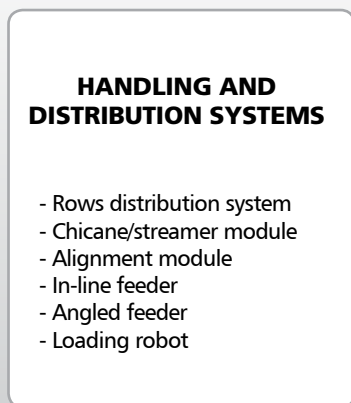
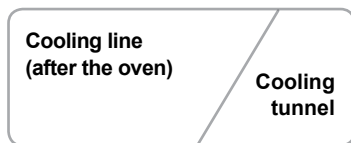

# SECTOR

## BAKERY



Snack cakes



Pastry



Bread



Pizzas, wraps and tortillas



Buns

## BISCUITS



Biscuits



Crackers, wafers ...

## CONFECTIONERY



Snack bars



Chocolates and sweets



# Snack cakes

The diversity of products, formats and presentations for snack cakes calls for flexible and efficient individual and multipack product packaging solutions, including re-closable and easy-opening designs.

Our offer ranges from manual loading machines to systems featuring integrated automatic loading and unloading and end-of-line units through to palletization.

- ▶ *A range of diverse formats: flexible, rigid and carton.*



FLOW PACK

► Re-closable packs.



FLOW PACK - SHRINK



FLOW PACK - MAP



THERMOFORMING



FLOW PACK



VERTICAL



► Single and multipack.





# Snack cakes

The diversity of products, formats and presentations for snack cakes calls for flexible and efficient individual and multipack product packaging solutions, including re-closable and easy-opening designs.

Our offer ranges from manual loading machines to systems featuring integrated automatic loading and unloading and end-of-line units through to palletization.



FLOW PACK



► Packages that display and protect the product.

THERMOFORMING



SHRINK



# Pastry

This delicate and fragile product, usually presented on a tray, requires specific solutions for individual packaging and for packaging in groups.

Tray denesting and loading may be performed automatically, increasing the effectiveness and productivity of the line.



FLOW PACK



FLOW PACK - SHRINK

- ▶ Automatic tray denesting.
- ▶ Single and group packaging on trays or in packs that protect the integrity of the product.

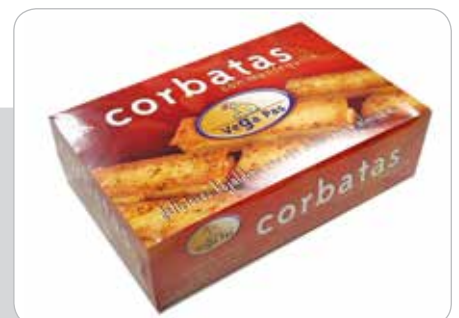



# Bread

Fermented products call for packaging solutions which, in addition to enhancing the image of the product, contribute to their preservation with packages that safeguard freshness and humidity. Optionally, in the case of certain packs, modified atmosphere conditions can be provided that will extend the product's shelf life.



FLOW PACK



FLOW PACK - MAP



VERTICAL



TRAYSEALING



▶ *Modified atmosphere packaging solutions.*

▶ *Solutions for different types of bread.*

THERMOFORMING





FLOW PACK



► Packages to extend product shelf life.

► Re-closable packs.

► Steady bottom packs.

THERMOFORMING



VERTICAL



FLOW PACK



# Pizzas, wraps, tortillas ...

Owing to the nature, sale format and consumer habits of these products, they are piece packaged and packed in groups, requiring packs that allow a part of the contents to be consumed while leaving the rest for later.

- ▶ *Modified atmosphere packaging solutions.*
- ▶ *Re-closable solutions by means of zippers, labels or adhesive stripes designed to keep the remaining product fresh.*



FLOW PACK

FLOW PACK - MAP

THERMOFORMING



Owing to the nature, sale format and consumer habits of these products, they are piece packaged and packed in groups, requiring packs that allow a part of the contents to be consumed while leaving the rest for later.

- ▶ *Easy opening systems.*
- ▶ *Re-closable packs.*

VERTICAL



FLOW PACK - MAP



FLOW PACK



# Snack cakes

Packaging line for cupcakes, involving product depanning and loading on Flow pack lines for single packaging. Integration of a secondary packaging cell including automatic group loading and vertical machine wrapping, for the final presentation of a bag with re-closable clip.

## Primary packaging

The product from the oven is automatically depanned by a robot which places it on the Flow pack machine feeder for individual packaging.

Depanning directly onto the Flow pack machine feeder by means of robots

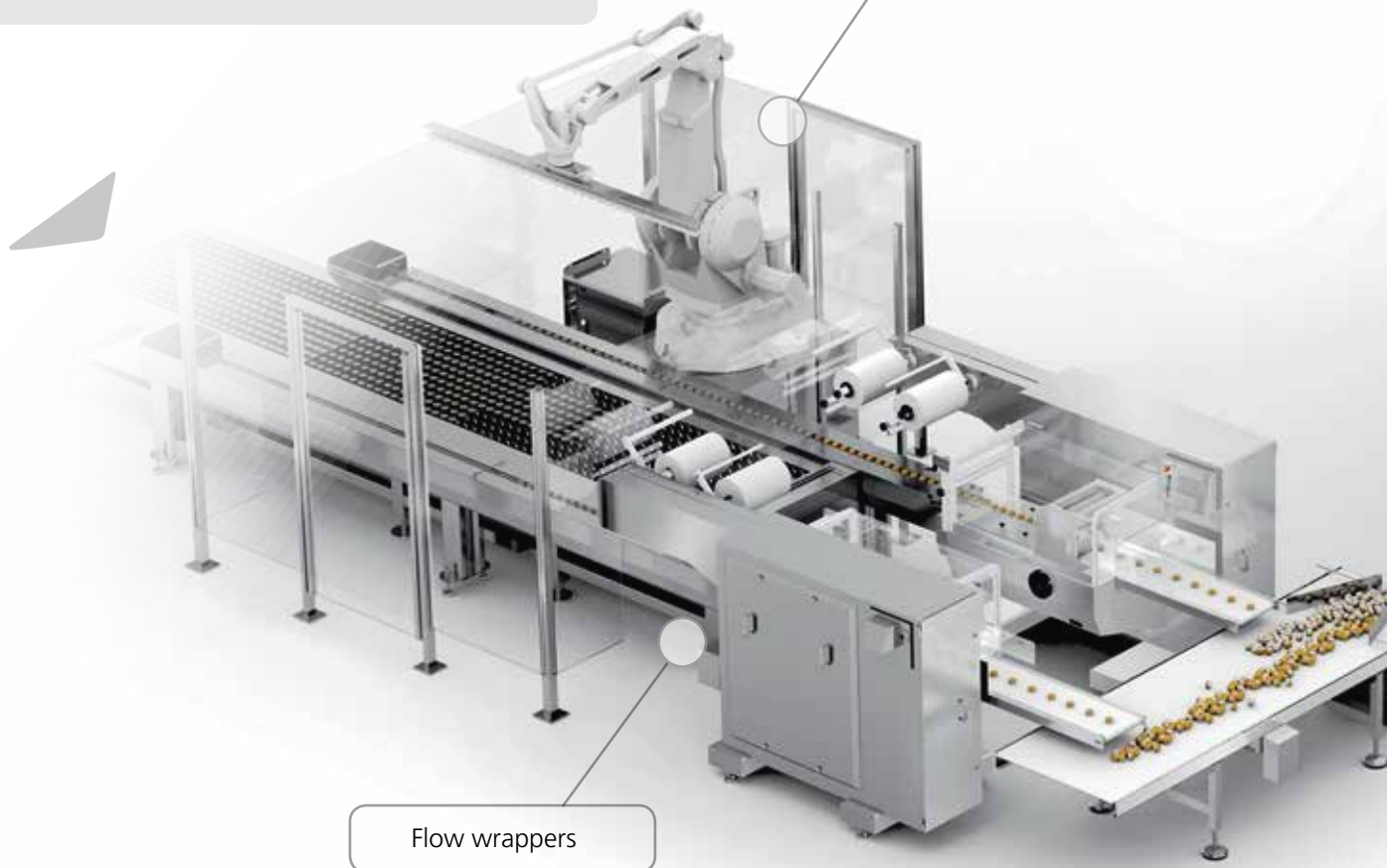



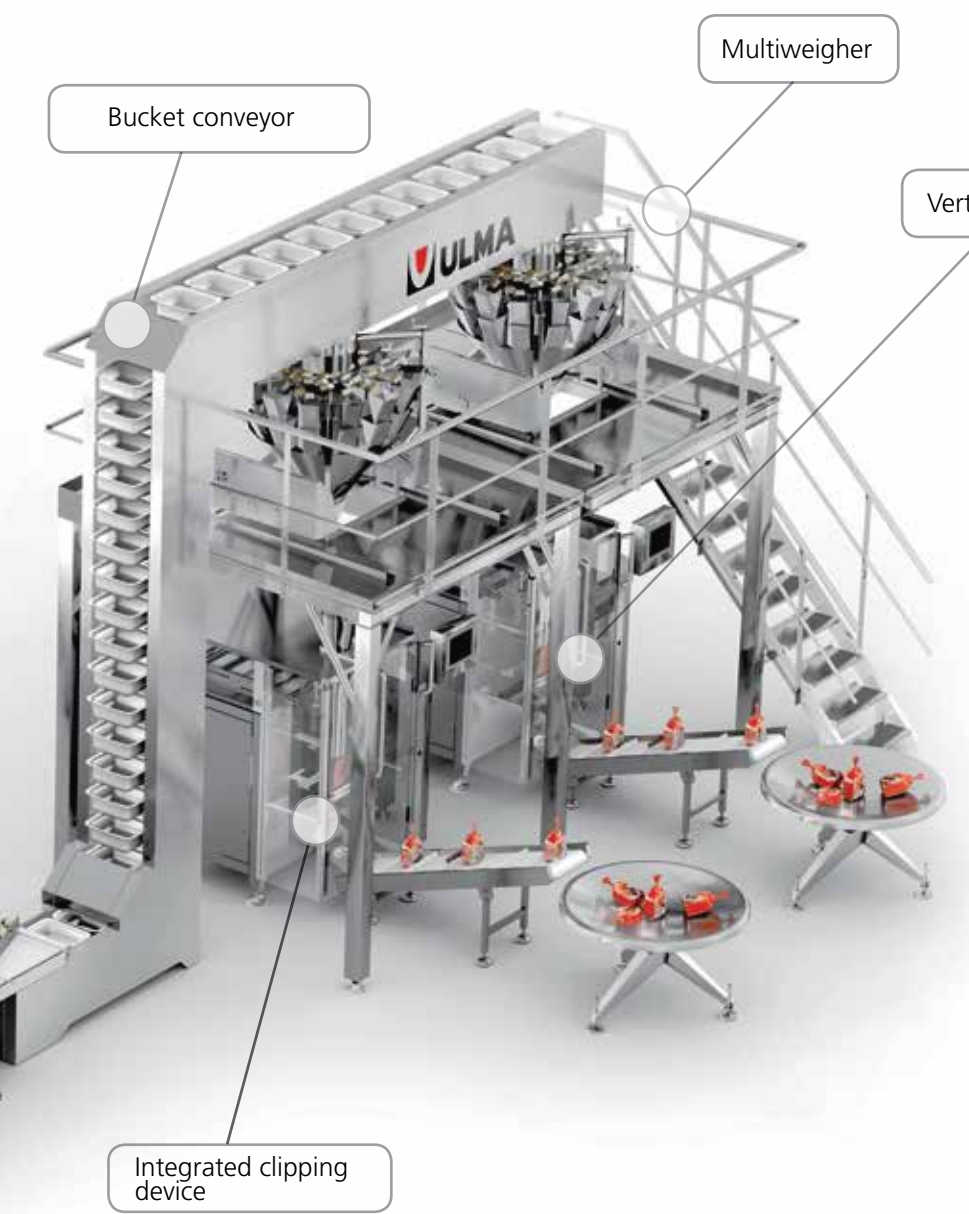

Bucket conveyor

Multiweigher

Vertical twin

Integrated clipping device

**Secondary packaging**  
 The product in primary packaging is carried to the multiweighers fed by two vertical machines.

The option to process re-closable clip bags is integrated in the machine and can be selected on-screen.



# Snack cakes

Packaging system for snack cakes incorporating several high speed wrapping lines. The product reaches these lines from a rows distributor system.

The wrapping lines include a continuous cardboard sheeter to cut and feed the cardboard in synchrony with the product.

The system receives the products arranged in rows from the cooling line and distributes them automatically to the packaging lines.

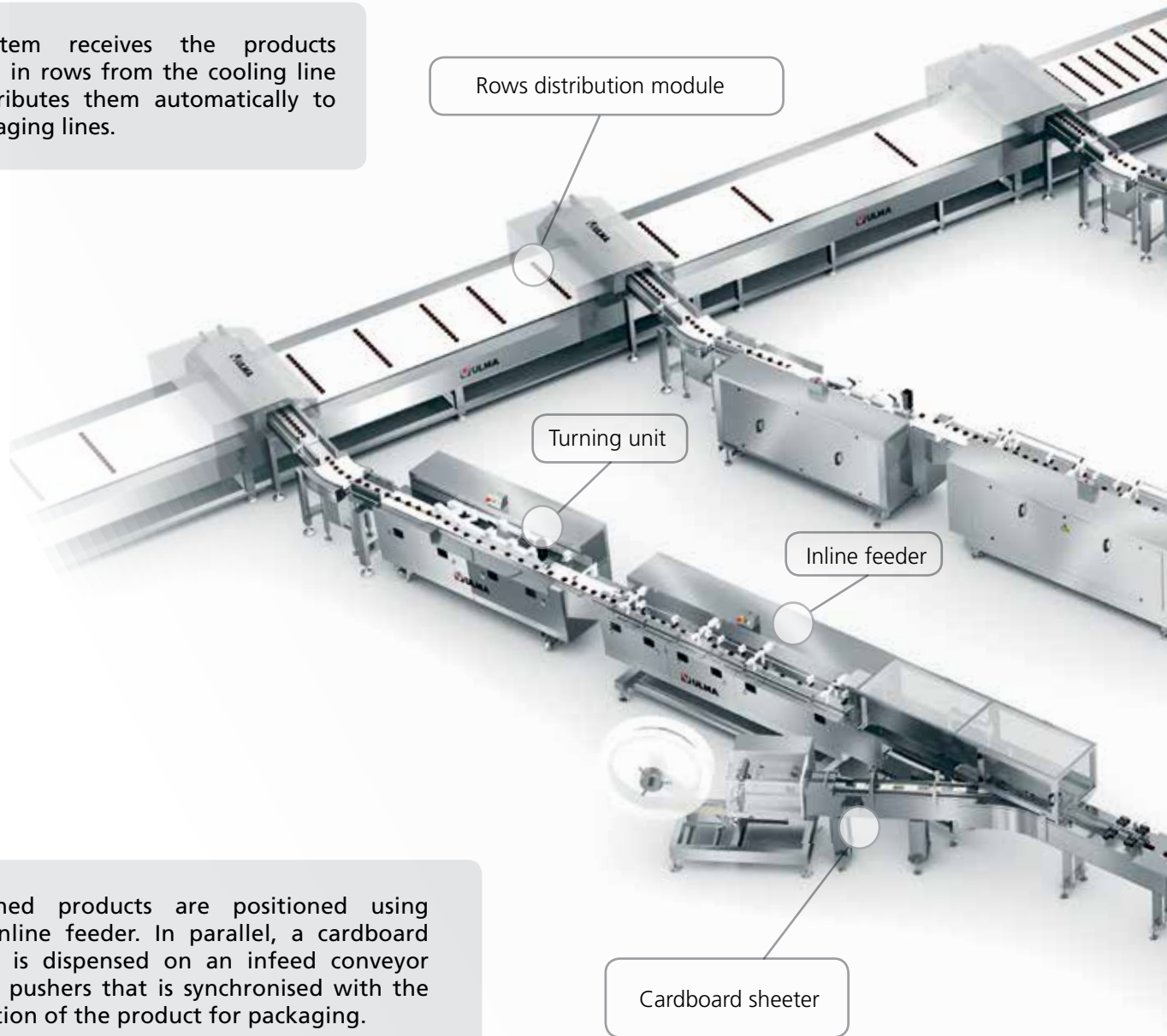

Aligned products are positioned using an inline feeder. In parallel, a cardboard base is dispensed on an infeed conveyor with pushers that is synchronised with the position of the product for packaging.





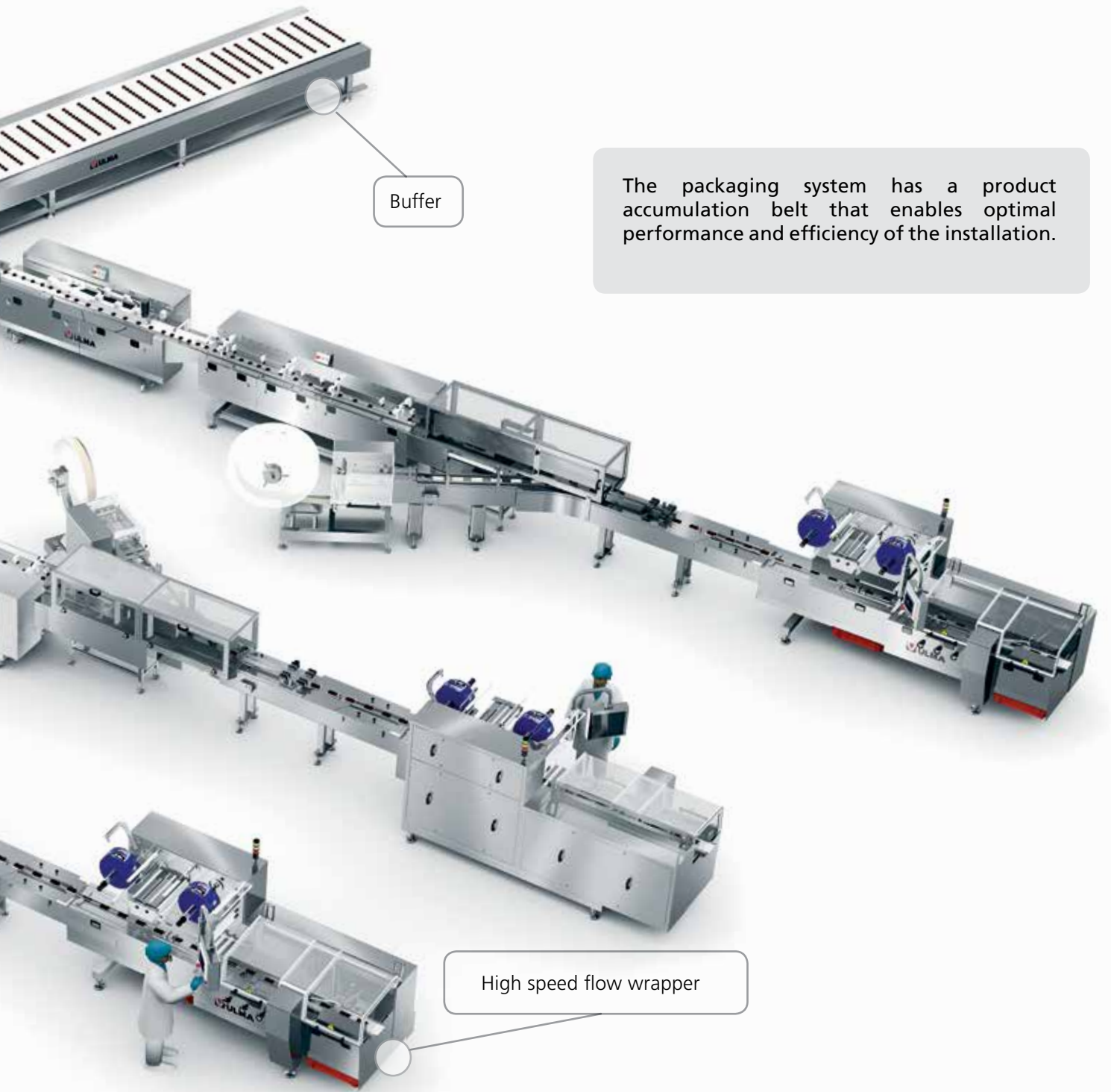

Buffer

The packaging system has a product accumulation belt that enables optimal performance and efficiency of the installation.

High speed flow wrapper



# Biscuits

The huge variety of biscuit types (laminated, deposited, wirecut ...) along with the different shapes and presentations (single, piled, on-edge, multipack ...) and the importance of the visual aspect at the point of sale, require alternative packaging solutions for these products including high speed infeed systems.



VERTICAL



- ▶ Individual packaging in strings with intervals programmable on a screen.

FLOW PACK



# Crackers, wafers ...



► Single packages, group packages, multipack ...



FLOW PACK

FLOW PACK

# Biscuits

Complete packaging line for biscuits from the production process which, by means of an automatic load system comprising vision and quality control, feeds the aligned product to the Flow pack for primary packaging.

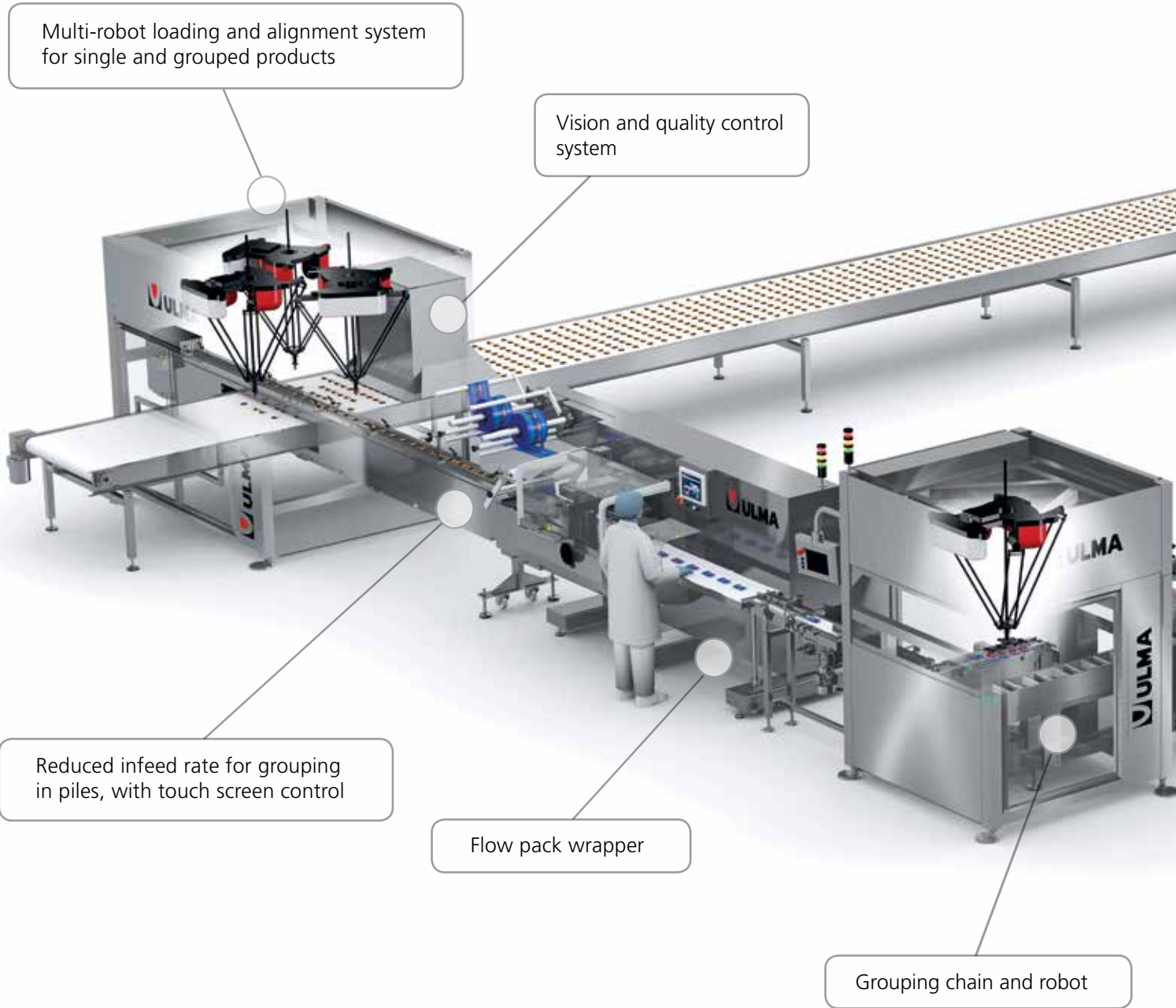



The product travels from the Flow pack to an automatic cartoner on a "grouping chain" for packing in cartons and subsequently in boxes. This includes forming, transporting and positioning the boxes in the box filling and closing area.

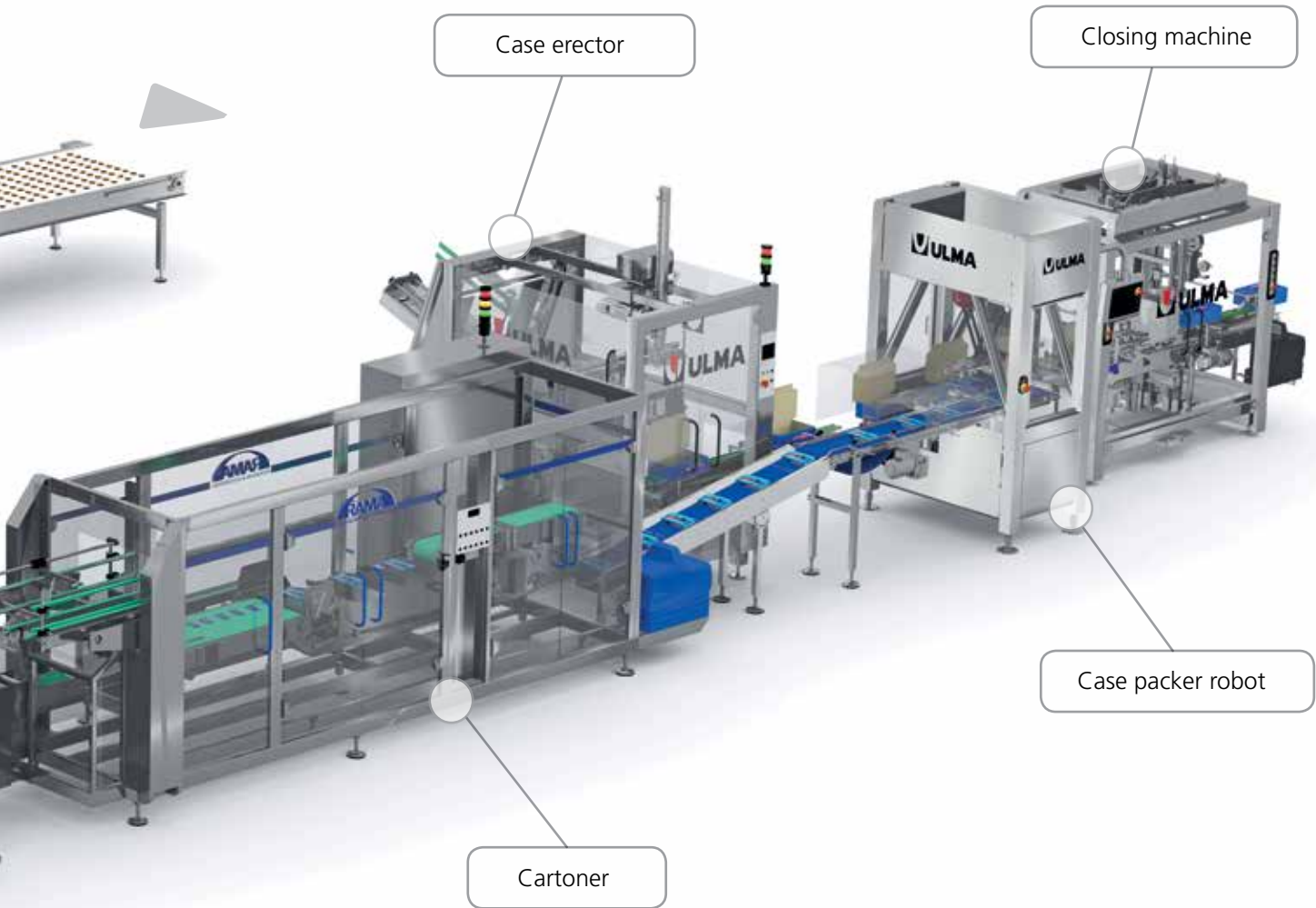

# Crackers

Automatic packaging line for grouped on-edge products. Crackers from an extruder are placed on several lanes that carry and turn the products to feed a volumetric loader that unload portions onto the Flow pack machine conveyor.

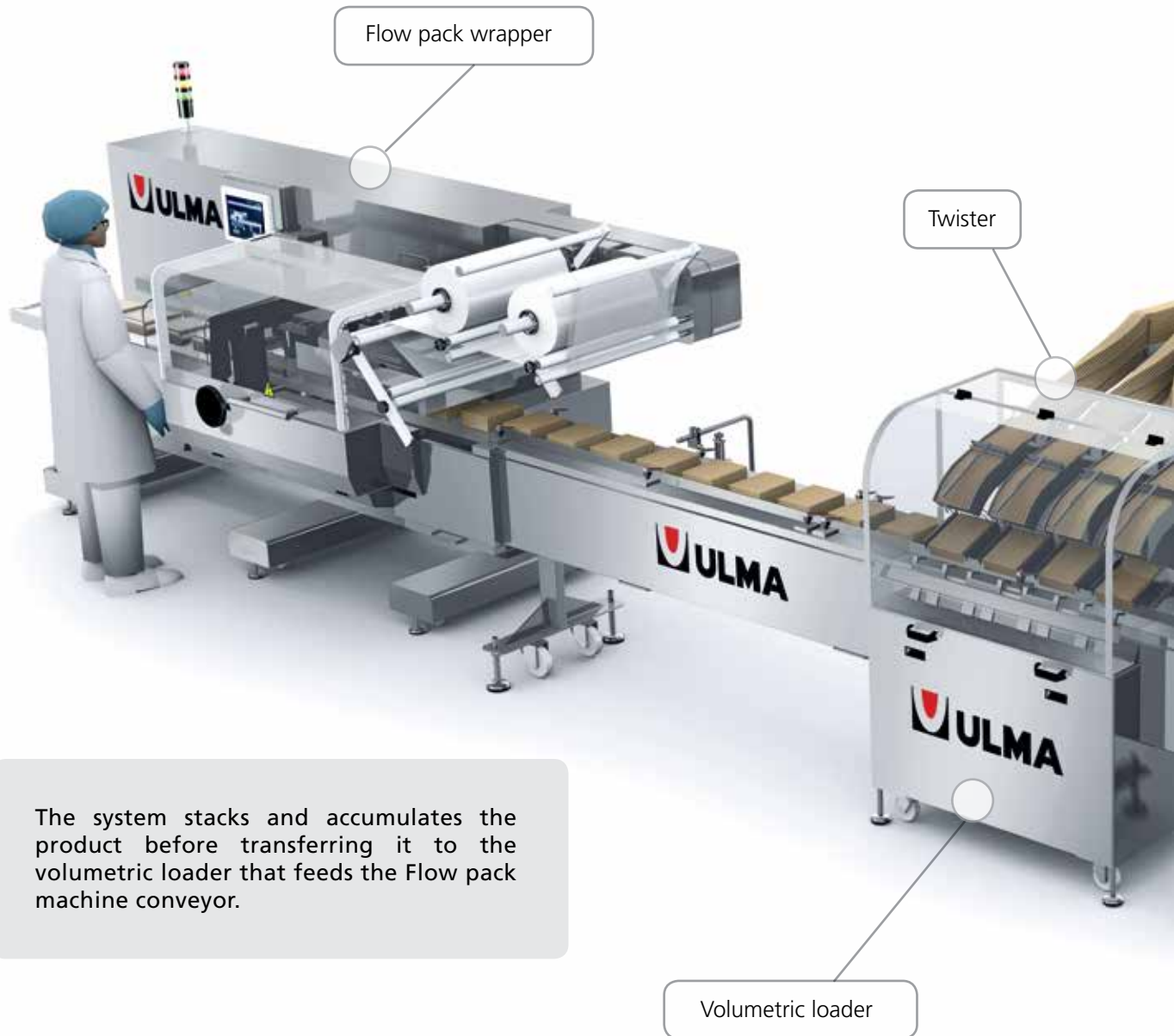

The system stacks and accumulates the product before transferring it to the volumetric loader that feeds the Flow pack machine conveyor.





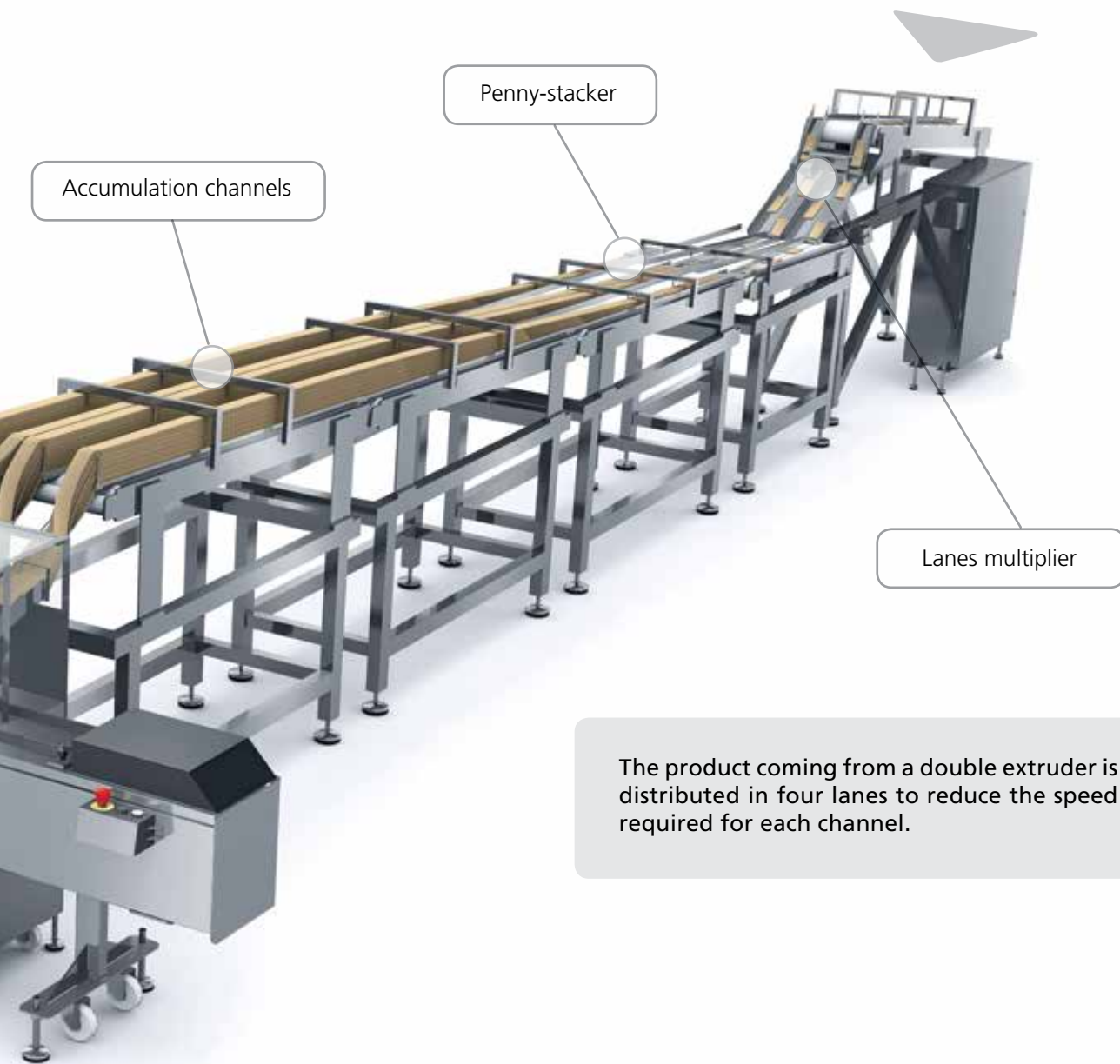

The product coming from a double extruder is distributed in four lanes to reduce the speed required for each channel.



# Snack bars

Snack bars and products with chocolate require packages that protect the product during handling and transporting, while ensuring an attractive presentation that appeals to the end user.

► Cardboard dispensing systems.





# Chocolates and sweets

Option for packaging in multiple formats and packs, adaptable to any shape and size.

FLOW PACK



FLOW PACK & VERTICAL



FLOW PACK-SHRINK



▶ Individual and multipack packaging for bars and tablets with hot and cold sealing.

▶ Steady bottom packages.



THERMOFORMING



VERTICAL



# Snack bars

Packaging system for snack bars made up of several high speed wrapping lines. The product reaches the wrapping lines from a rows distributor system. The automatic packaging systems are designed to facilitate cleaning tasks on all conveyors and to minimize areas with restricted access.

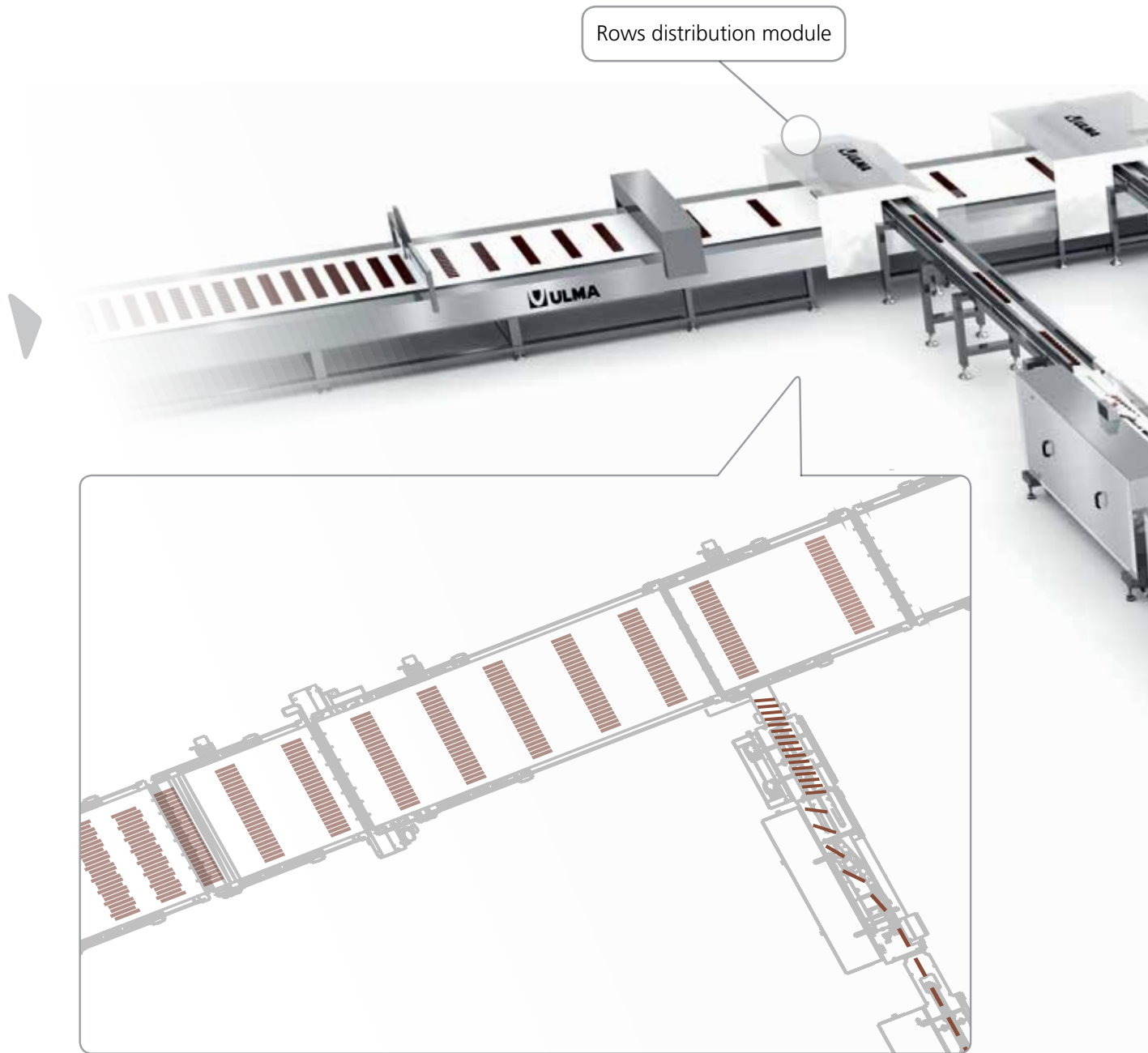



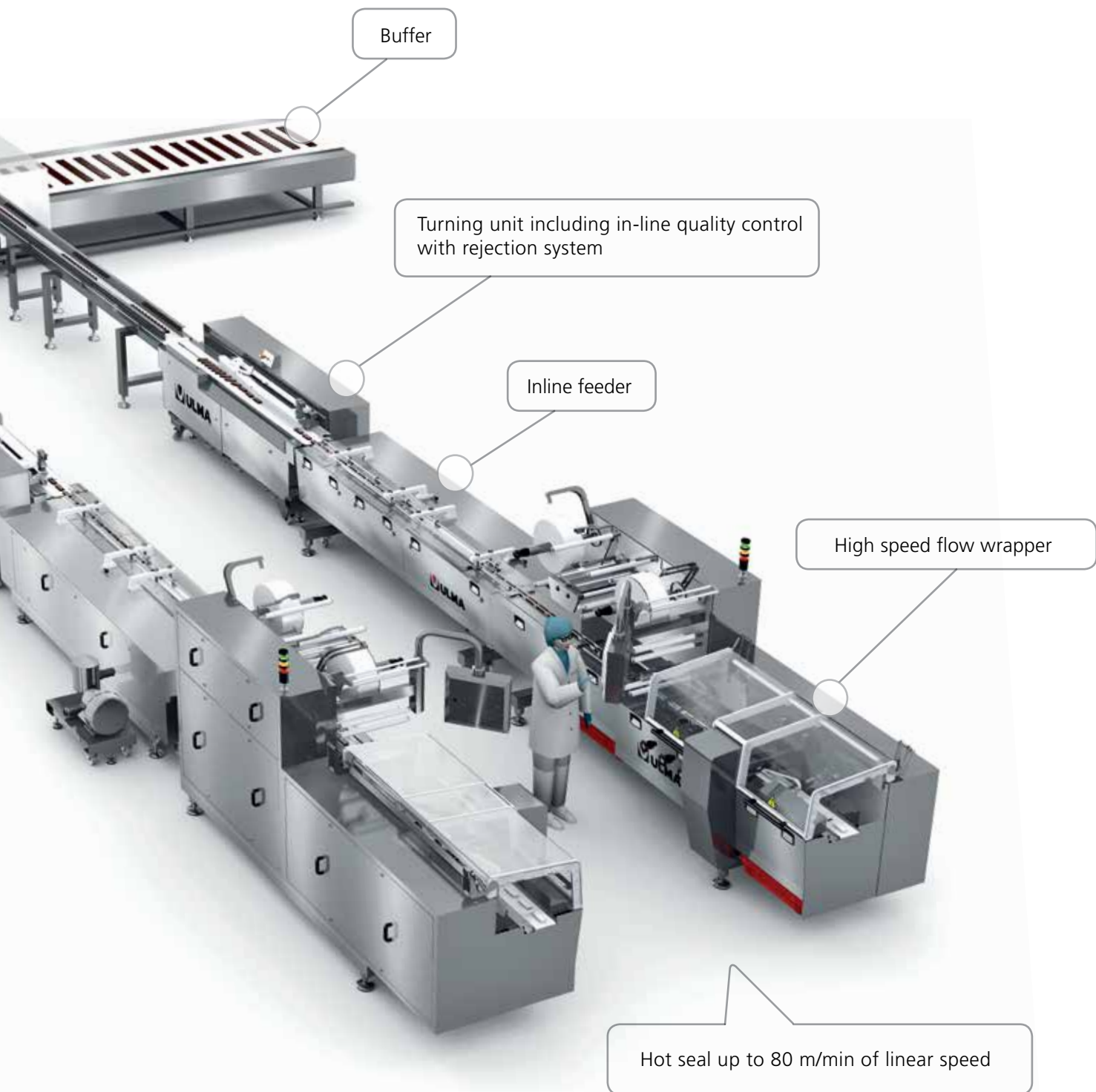

# Snack bars

Packaging line for chocolate covered cereal bars. An angled twin belt system extends the rows coming from the cooling tunnel, prior to feeding the high speed packaging unit.



High speed hot and cold sealing systems.



A high speed jaw replacement system allows the most appropriate method to be applied for each different hot or cold seal film type, thus ensuring the integrity of the seal.

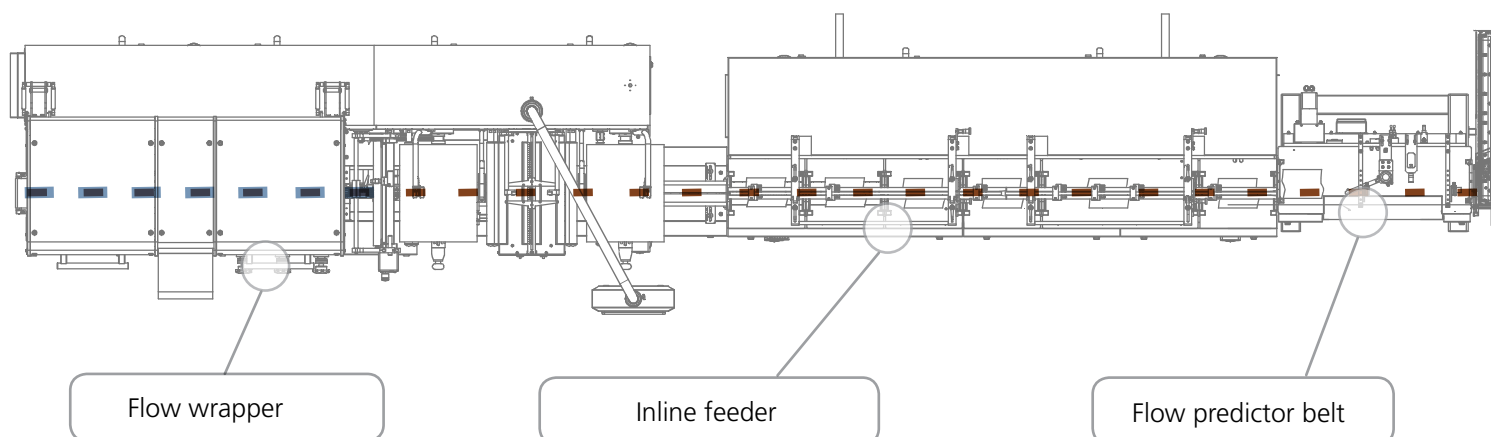





The rows of product from the cooling tunnel are extended by means of an angled double belt system that facilitates product alignment, necessary before entering the automatic infeed system.

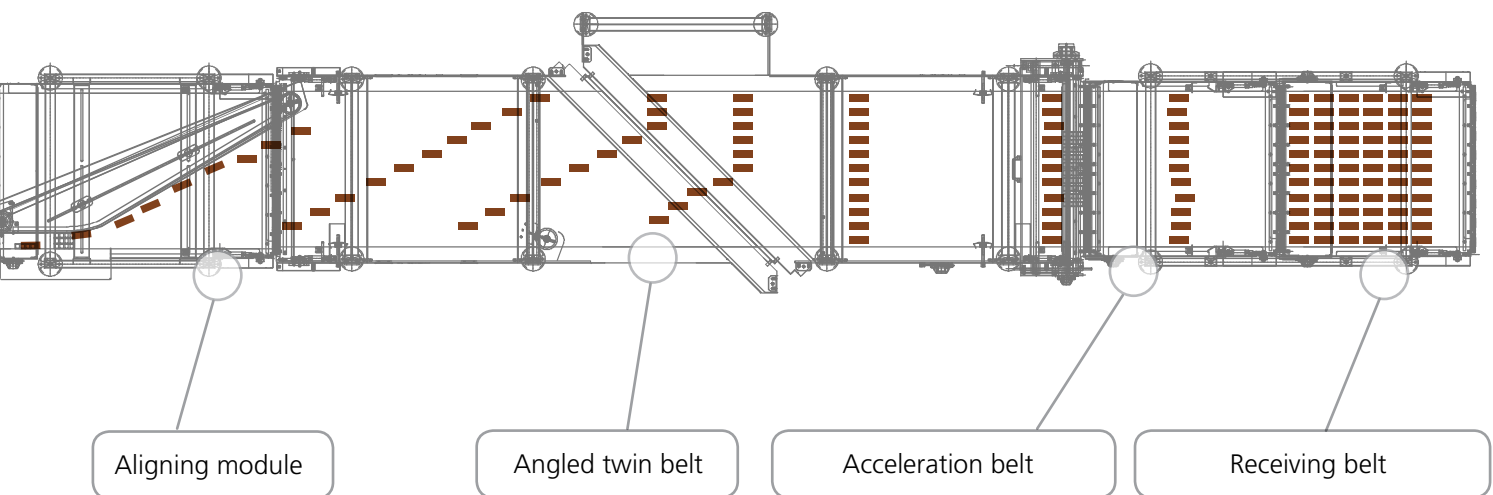

# Chocolates

Automatic individual packaging line for chocolate bars in thermoformed packs that keep the product shape. This line incorporates an integrated vision and quality control system as part of the automatic loading system with an accumulation buffer for optimal packaging performance and efficiency.

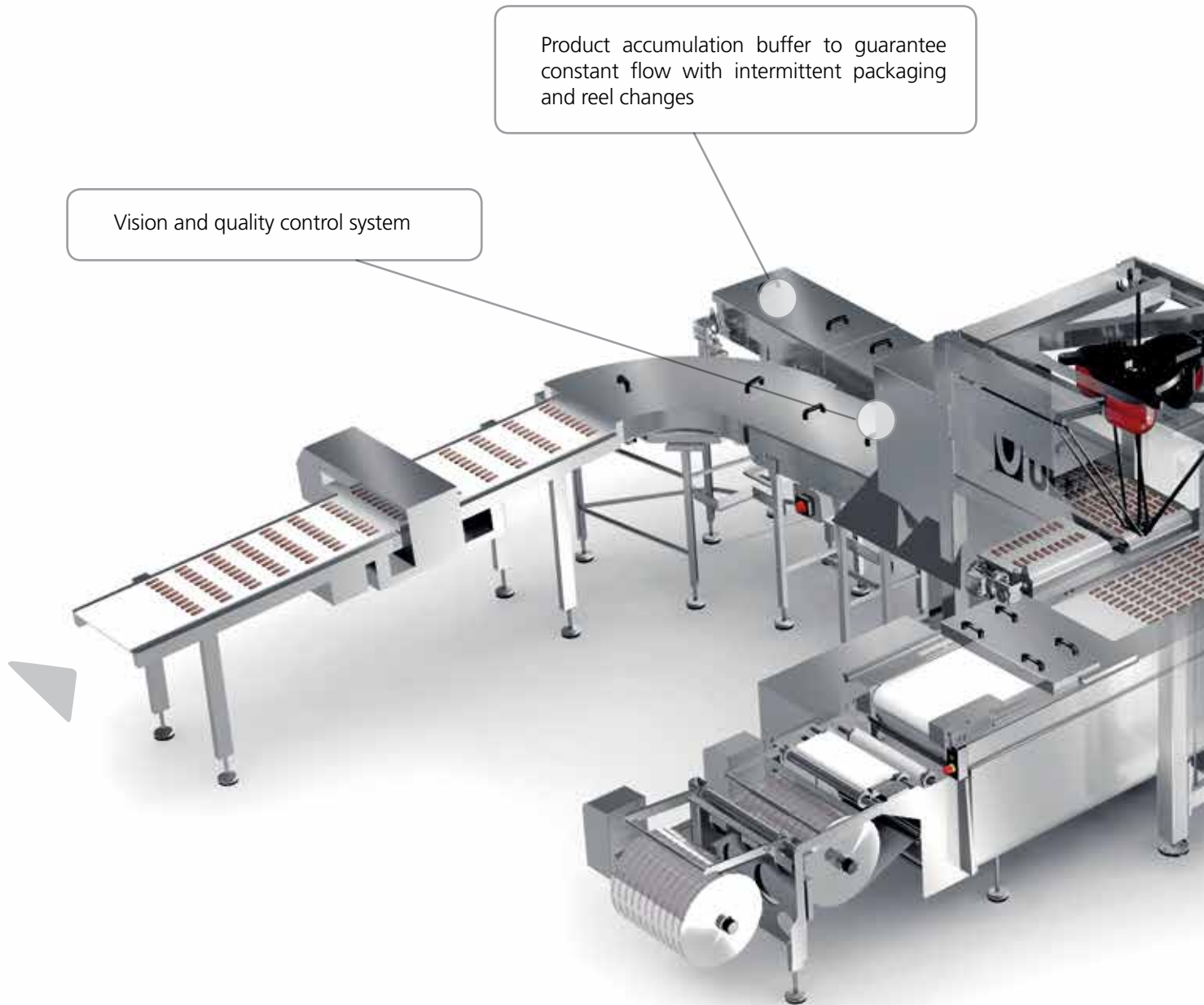



"Delta" type loading robot for automatic machine infeed

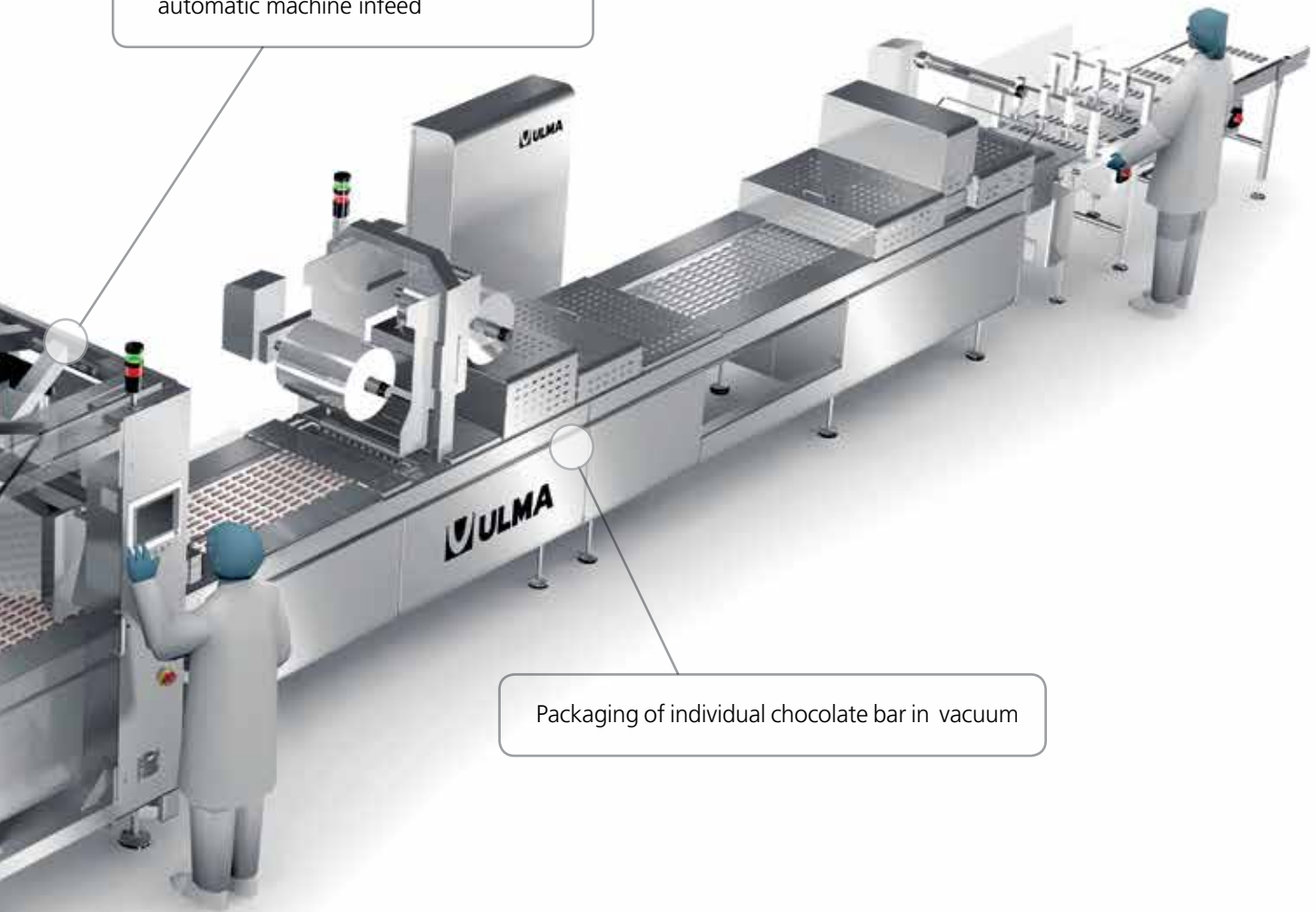

Packaging of individual chocolate bar in vacuum



# Complete automated line

Automatic muffin line from the product distribution to final palletizing.

## Automatic horizontal cartoning

- Control and accumulation of packed product
- Handling and loading with ULMA D12H robot
- Horizontal cartoner for grouped packages
- Inspection system



## Case packing and palletization

- Carton accumulation and loading
- "Wrap around" case packing of grouped cartons
- Palletization, bundling, labelling and pallet removal

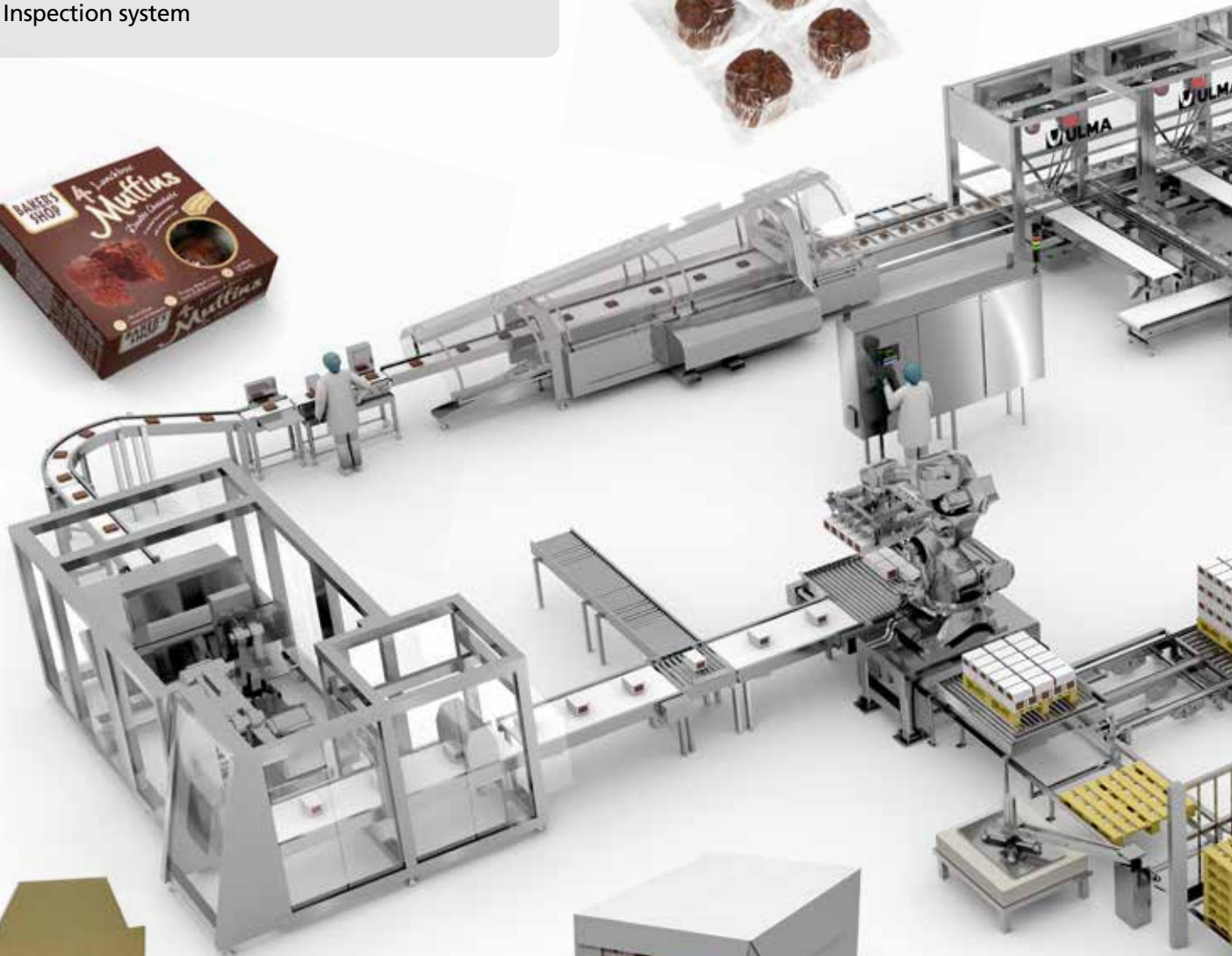



## Flow wrapping

- Alignment and rows separation
- Distribution to several packaging lines
- Automatic product feed
- Primary packaging flow wrapper

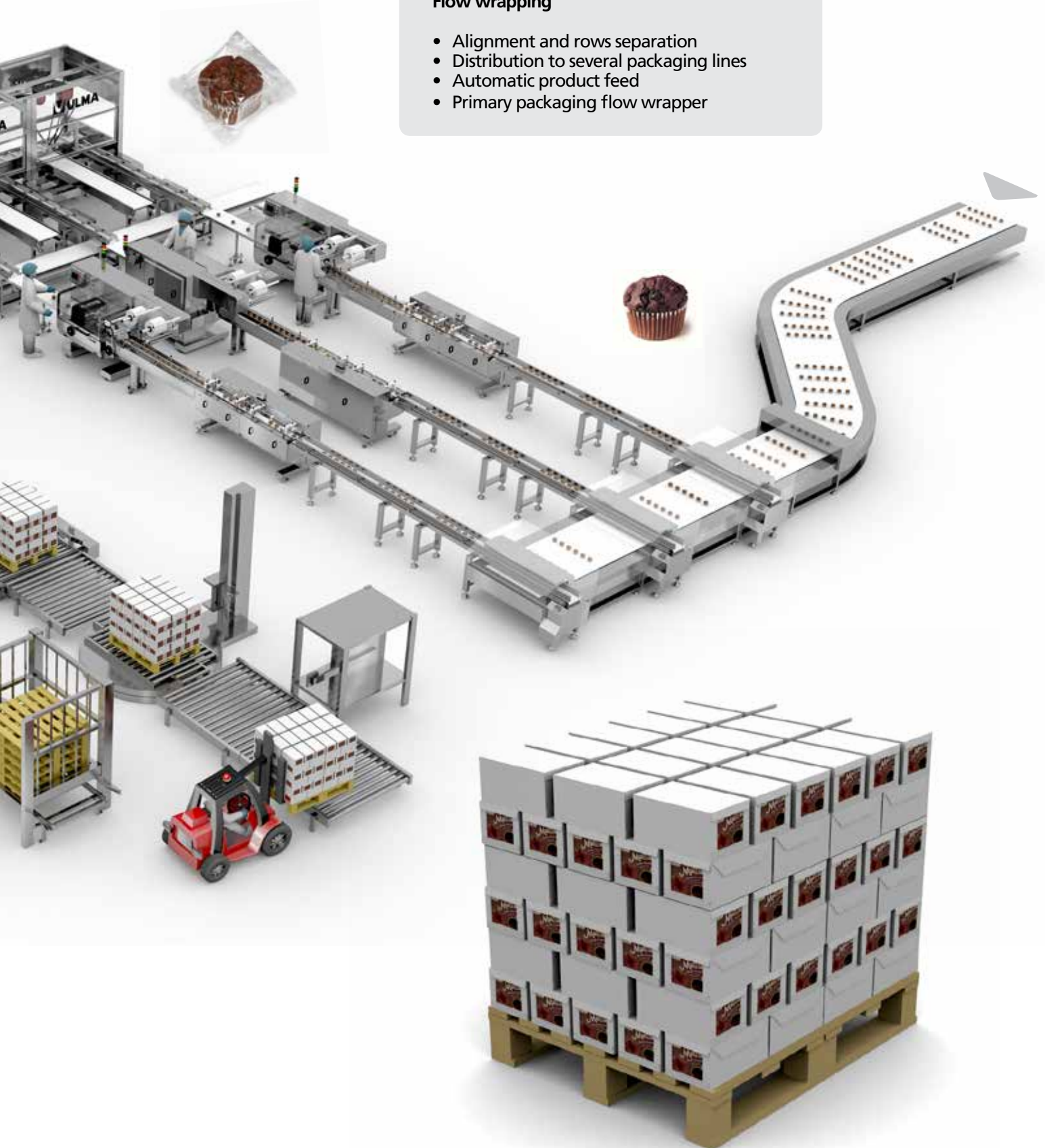

# Service

## The ULMA advantage

At ULMA Packaging we are dedicated to work in close collaboration with our clients, which has become our key to customer satisfaction. Our Customer Focus through Service Excellence is the unique ULMA Advantage.



### Training

- Training conducted by a team of specialists.
- Our training includes both courses at ULMA and onsite installations.
- ULMA offers modern communication technology for holding long-distance training, including video conferencing.
- Training is conducted during start-up and full production. The training includes technical detail of how to effectively use, clean and maintain the machine, along with important safety training.



### Preventative Maintenance

Maintaining your packaging machines in good working conditions assures higher productivity and profitability, and a shorter recovery time of your investment.

ULMA offers customized preventive maintenance service including visits at regular intervals over the year by a trained technical ULMA specialist, who will thoroughly inspect the equipment, focusing on the major mechanisms, controls and safeties of the machine.



### Spare Parts

- Machine spare parts in more than 20 countries ensures availability in the least amount of time possible.
- Original spare parts, of the highest quality.
- Guaranteed delivery of standard spare parts to any part of the world within 24 hours via express service and 3-4 days via normal service and for non-standard parts.
- ULMA guarantees the availability of any spare part for at least 10 years after the machine's initial supply.



### Technical Service

- We have highly qualified technicians in all countries around the world, providing a locally based, fast service.
- We offer extra services for special promotional periods.
- A Broad Service Availability, offers access to resources and the ease of contact from anywhere in the world.
- Immediate telephonic technical support via technical experts specialised in each product line.
- Remote assistance via the Internet, enabling our programmers to remotely take control of your machine and diagnose problems.
- Option to purchase various spare part kits with the machine.
- Retrofitting of machines already installed to new formats or applications.



### ULMA Packaging

Thanks to an experience of more than 50 years, we are a worldwide reference in the design and manufacturing of high-tech packaging systems and equipment.

More than 50 years evolving, innovating, perfecting our technology and our services. An extensive network that is available to offer you solutions anywhere in the world, and to fully satisfy customers that place their trust in us.

For additional information, please visit our website:

[www.ulmapackaging.com](http://www.ulmapackaging.com)



ULMA Packaging, S. Coop.  
Bº Garibai, 28 - Apdo. 145  
20.560 OÑATI (Gipuzkoa) SPAIN  
Tel.: +34 - 943 73 92 00  
Fax: +34 - 943 78 08 19  
Web: [www.ulmapackaging.com](http://www.ulmapackaging.com)  
e-mail: [info@ulmapackaging.com](mailto:info@ulmapackaging.com)